

INSERTED SPOT DRILL CENTER CUTTING INSERTS

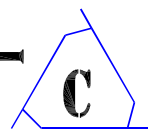

TWO FLUTE RADIAL RELIEF SPOT DRILL INSERTS

PATENT No. 7540-696

.010 to .150 Outside Diameter

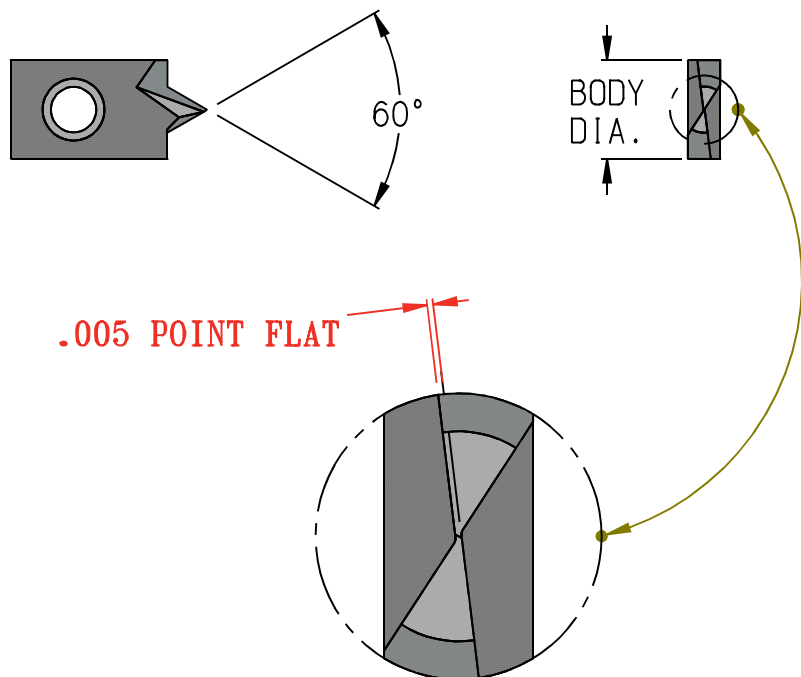

60° INSERTS		Right Hand Shown	
PLAIN TYPE	INSERT No.	POINT FLAT	BODY DIA.
#2	RSDI-2-60-005	.005	.250
#3	RSDI-3-60-005	.005	.375

60° INCLUDED RADIAL SPOT DRILL INSERT ADVANTAGES

USE SDH HOLDERS ON PAGE 3

- 1) THE 60° INCLUDED ANGLE HAS RADIAL AND CONICAL RELIEF THAT IS OFFSET TO GIVE THE CUTTING EDGE MAXIMUM STRENGTH PLUS CLEARANCE.
- 2) THESE TWO SPOT DRILL INSERTS ARE CENTER CUTTING WITH THE ABILITY TO SPOT MATERIAL STARTING WITH A OUTSIDE DIAMETER OF .010.
- 3) THE SPEEDS FOR THESE TWO INSERTS NEED TO BE BETWEEN 5000 R.P.M. AND 8000 R.P.M. PLUS THE FEED RATE SHOULD BE BETWEEN .500 AND 1.000 INCH PER MINUTE.

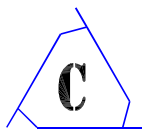

INSERTED SPOT DRILL CENTER CUTTING INSERTS

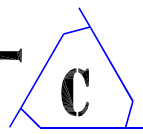

TWO FLUTE STANDARD RELIEF SPOT DRILL INSERTS

" SPADE TYPE SPOT DRILL INSERTS AVAILABLE UPON REQUEST "

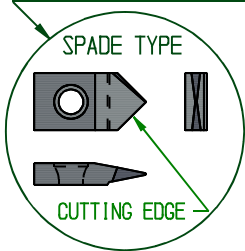

PATENT No. 7540-696

LETTER DESIGNATION	POINT FLAT
F = FINE POINT FLAT	.005
M = MEDIUM POINT FLAT	.015
H = HEAVY POINT FLAT	.034

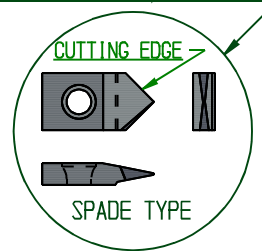

Left Hand

Ordering EXAMPLE
SDI-2-82-F-LH

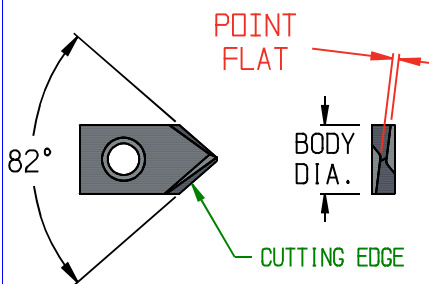

82° INSERTS

PLAIN TYPE	INSERT No.	POINT FLAT	ADD -LH FOR LEFT HAND	BODY DIA.
#2	SDI-2-82	F / M / H	SEE EXAMPLE	.250
#3	SDI-3-82	F / M / H	SEE EXAMPLE	.375
#4	SDI-4-82	F / M / H	SEE EXAMPLE	.500

Right Hand

Ordering EXAMPLE
SDI-2-82-F

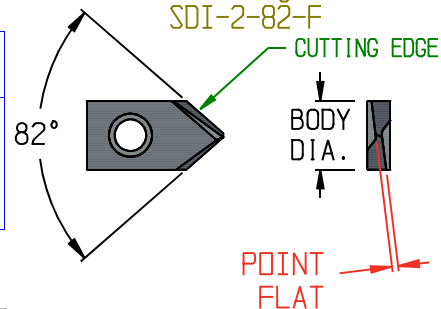

Left Hand

Ordering EXAMPLE
SDI-3-90-M-LH

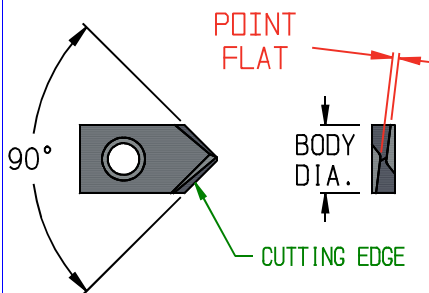

90° INSERTS

PLAIN TYPE	INSERT No.	POINT FLAT	ADD -LH FOR LEFT HAND	BODY DIA.
#2	SDI-2-90	F / M / H	SEE EXAMPLE	.250
#3	SDI-3-90	F / M / H	SEE EXAMPLE	.375
#4	SDI-4-90	F / M / H	SEE EXAMPLE	.500

Right Hand

Ordering EXAMPLE
SDI-3-90-M

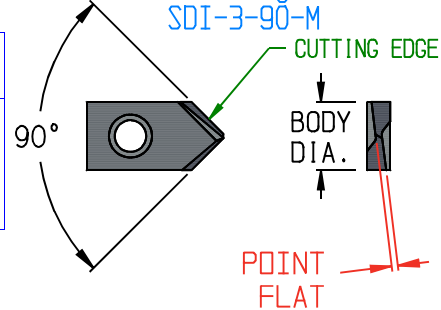

Left Hand

Ordering EXAMPLE
SDI-4-120-H-LH

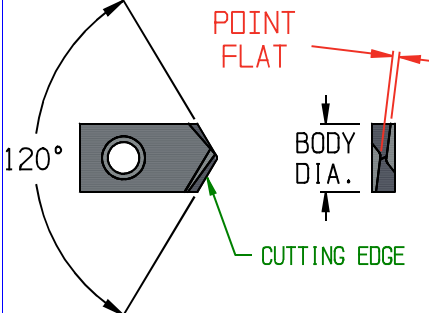

120° INSERTS

PLAIN TYPE	INSERT No.	POINT FLAT	ADD -LH FOR LEFT HAND	BODY DIA.
#2	SDI-2-120	F / M / H	SEE EXAMPLE	.250
#3	SDI-3-120	F / M / H	SEE EXAMPLE	.375
#4	SDI-4-120	F / M / H	SEE EXAMPLE	.500

Right Hand

Ordering EXAMPLE
SDI-4-120-H

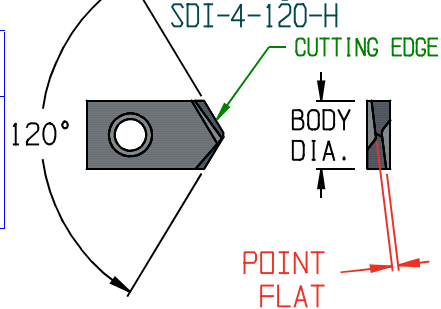

SEE PAGE #3 FOR HOLDERS

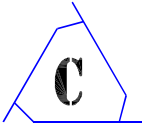

INSERTED SPOT DRILL TOOLHOLDERS

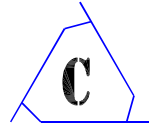

PATENT No. 7540-696

SEE INSERTS PAGES #1, #2.

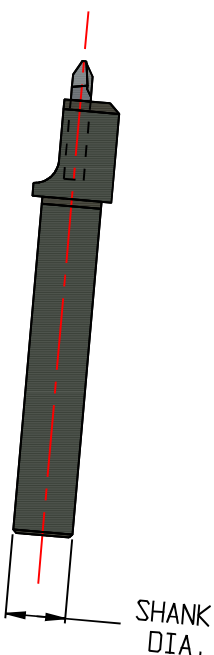
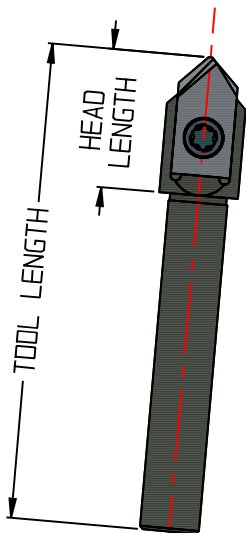
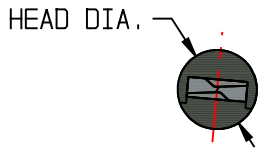

PLAIN TYPE #2

TOOLHOLDER No.	TOOL LENGTH	SHANK DIA.	HEAD DIA.	HEAD LENGTH	SCREW No.	WRENCH No.
SDH-2-250-2.0	2.0	.250	.405	.690	CTD-3126	CTD-3344
SDH-2-375-1.5	1.5	.375	-----	-----	CTD-3126	CTD-3344
SDH-2-375-2.5	2.5	.375	-----	-----	CTD-3126	CTD-3344
SDH-2-500-2.0	2.0	.500	-----	-----	CTD-3126	CTD-3344
SDH-2-500-3.0	3.0	.500	-----	-----	CTD-3126	CTD-3344
SDH-2-625-5.0	5.0	.625	-----	-----	CTD-3126	CTD-3344
SDH-2-750-5.0	5.0	.750	-----	-----	CTD-3126	CTD-3344
SDH-2-1.000-5.0	5.0	1.000	-----	-----	CTD-3126	CTD-3344
SDH-2-10MM-1.5	1.5	10MM	-----	-----	CTD-3126	CTD-3344
SDH-2-10MM-2.5	2.5	10MM	-----	-----	CTD-3126	CTD-3344

PLAIN TYPE #3

TOOLHOLDER No.	TOOL LENGTH	SHANK DIA.	HEAD DIA.	HEAD LENGTH	SCREW No.	WRENCH No.
SDH-3-375-2.0	2.0	.375	.625	.900	CTD-4110	CTD-4112
SDH-3-375-3.0	3.0	.375	.625	.900	CTD-4110	CTD-4112
SDH-3-500-2.0	2.0	.500	.625	.900	CTD-4110	CTD-4112
SDH-3-500-3.0	3.0	.500	.625	.900	CTD-4110	CTD-4112
SDH-3-625-3.0	3.0	.625	-----	-----	CTD-4110	CTD-4112
SDH-3-625-5.0	5.0	.625	-----	-----	CTD-4110	CTD-4112
SDH-3-750-3.5	3.5	.750	-----	-----	CTD-4110	CTD-4112
SDH-3-750-5.0	5.0	.750	-----	-----	CTD-4110	CTD-4112
SDH-3-1.000-5.0	5.0	1.000	-----	-----	CTD-4110	CTD-4112
SDH-3-10MM-2.0	2.0	10MM	.500	.900	CTD-4110	CTD-4112
SDH-3-10MM-3.0	3.0	10MM	.500	.900	CTD-4110	CTD-4112
SDH-3-16MM-3.0	3.0	16MM	-----	-----	CTD-4110	CTD-4112

PLAIN TYPE #4

TOOLHOLDER No.	TOOL LENGTH	SHANK DIA.	HEAD DIA.	HEAD LENGTH	SCREW No.	WRENCH No.
SDH-4-375-3.5	3.5	.375	.750	1.20	CTD-4111	CTD-4112
SDH-4-500-2.5	2.5	.500	.750	1.20	CTD-4111	CTD-4112
SDH-4-500-3.5	3.5	.500	.750	1.20	CTD-4111	CTD-4112
SDH-4-625-2.5	2.5	.625	.750	1.20	CTD-4111	CTD-4112
SDH-4-625-3.5	3.5	.625	.750	1.20	CTD-4111	CTD-4112
SDH-4-625-5.0	5.0	.625	.750	1.20	CTD-4111	CTD-4112
SDH-4-750-2.5	2.5	.750	-----	-----	CTD-4111	CTD-4112
SDH-4-750-3.5	3.5	.750	-----	-----	CTD-4111	CTD-4112
SDH-4-750-5.0	5.0	.750	-----	-----	CTD-4111	CTD-4112
SDH-4-1.000-5.0	5.0	1.000	-----	-----	CTD-4111	CTD-4112