

CARBIDE TRIANGULAR CUT OFF INSERTS

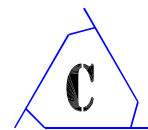

PATENT No. 8,734,064 B2

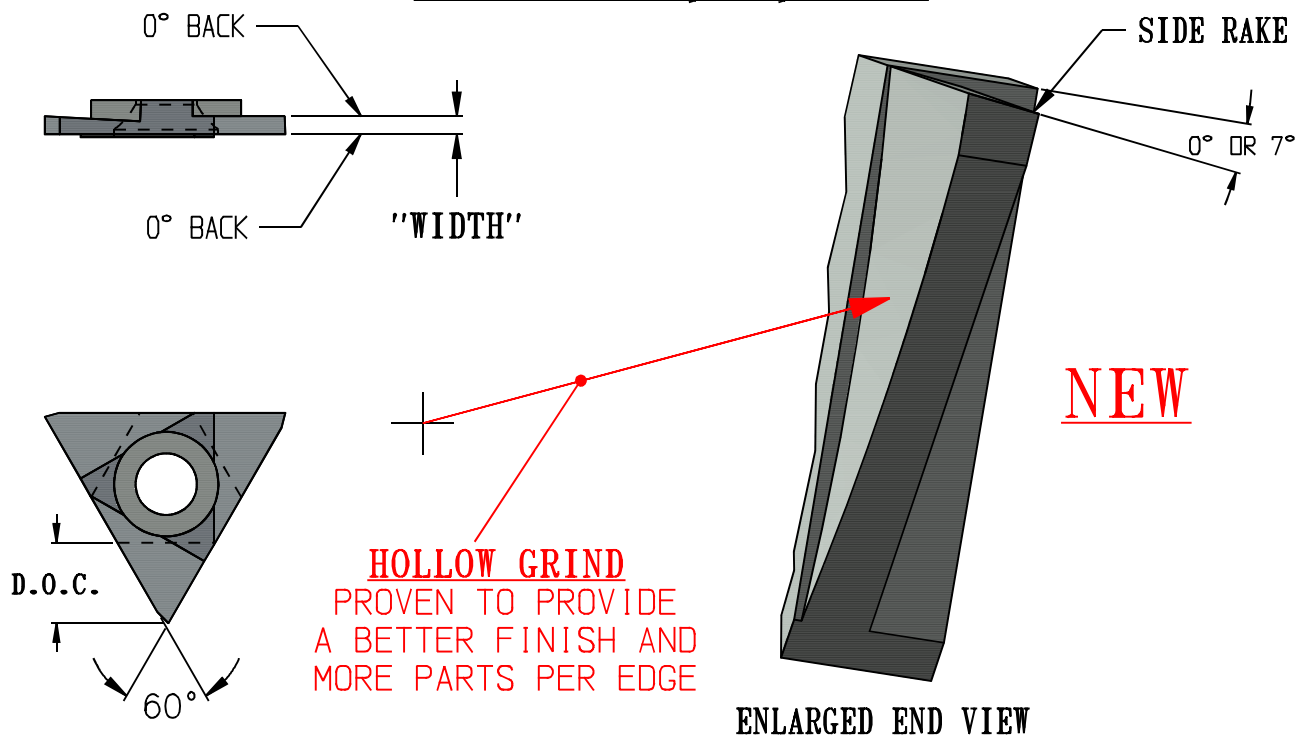

.500 I.C. INSERTS

0° SIDE RAKE INSERT	7° SIDE RAKE INSERT	"WIDTH"	D.O.C.	MAX. DIA CUT OFF
TLPL-031	CTD-9405-031L	.031	.150	.250
TLPL-047	CTD-9405-047L	.047	.281	.470
TLPL-063	CTD-9405-063L	.063	.281	.470
TLPL-078	CTD-9405-078L	.078	.281	.470
TLPL-094	CTD-9405-094L	.094	.281	.470
TLPL-125	CTD-9405-125L	.125	.281	.470

.625 I.C. INSERTS

0° SIDE RAKE INSERT	7° SIDE RAKE INSERT	"WIDTH"	D.O.C.	MAX. DIA CUT OFF
TIPL-063	CTD-9605-063L	.063	.345	.625
TIPL-078	CTD-9605-078L	.078	.345	.625
TIPL-094	CTD-9605-094L	.094	.345	.625
TIPL-125	CTD-9605-125L	.125	.345	.625

FOR TRIANGULAR INSERTED TOOLHOLDER INFORMATION, REFER TO PAGE 20 FOR DAVENPORT TOOLHOLDERS, AND PAGES 21 & 22 FOR THE CNC & SWISS TYPE TOOLHOLDERS.

TRIANGULAR INSERTED DAVENPORT CUT-OFF TOOLHOLDERS

DAVENPORT REGULAR C/O TOOLHOLDER

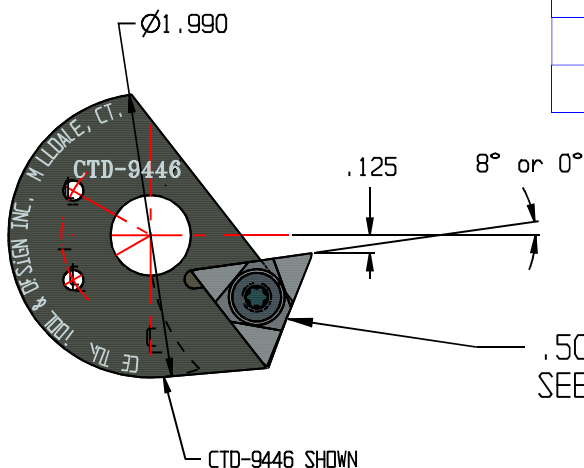

TOOLHOLDER No.	SCREW No.	WRENCH No.
CTD-9446	CTD-4857	CTD-3619
CTD-9446-0	CTD-4857	CTD-3619

ALTERNATE HEX SCREW AND WRENCH
ORDER AS CTD-9492 FOR SCREW AND
1/8 HEX FOR WRENCH

.500 I.C. TRIANGULAR INSERT
SEE PAGE #19 FOR INSERT INFORMATION

DAVENPORT OVERSIZE C/O TOOLHOLDER

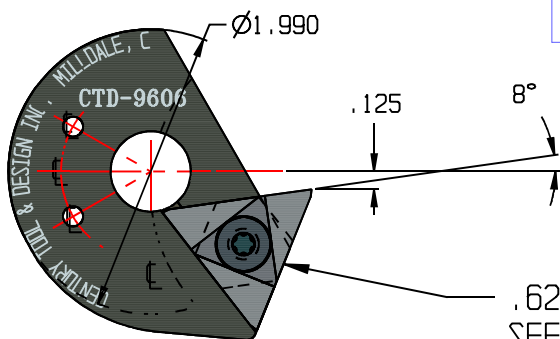
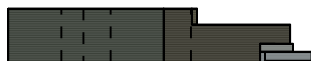

TOOLHOLDER No.	SCREW No.	WRENCH No.
CTD-9606	CTD-4857	CTD-3619

ALTERNATE HEX SCREW AND WRENCH
ORDER AS CTD-9492 FOR SCREW AND
1/8 HEX FOR WRENCH

.625 I.C. TRIANGULAR INSERT
SEE PAGE #19 FOR INSERT INFORMATION

TRIANGULAR INSERTED CNC & SWISS TYPE TOOLHOLDERS

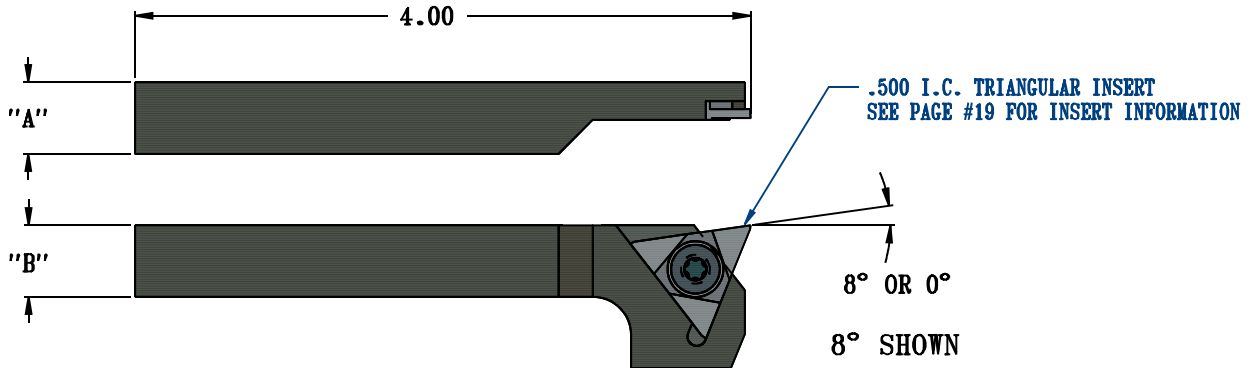
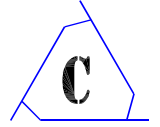
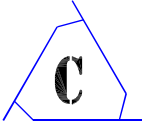

0° TOP RAKE TOOLHOLDERS	8° TOP RAKE TOOLHOLDERS	"A"	"B"	SCREW No.	WRENCH No.
CTD-9610-3	CTD-9611-3	.375	.375	CTD-4857	CTD-3619
CTD-9610-4	CTD-9611-4	.500	.500		
CTD-9610-5	CTD-9611-5	.625	.625		
CTD-9610-6	CTD-9611-6	.750	.750		
CTD-9610-8mm	CTD-9611-8mm	.315	.315		
CTD-9610-10mm	CTD-9611-10mm	.394	.394		
CTD-9610-12mm	CTD-9611-12mm	.472	.472		

ALTERNATE HEX
SCREW AND WRENCH
ORDER AS CTD-9492
FOR SCREW AND 1/8
HEX FOR WRENCH

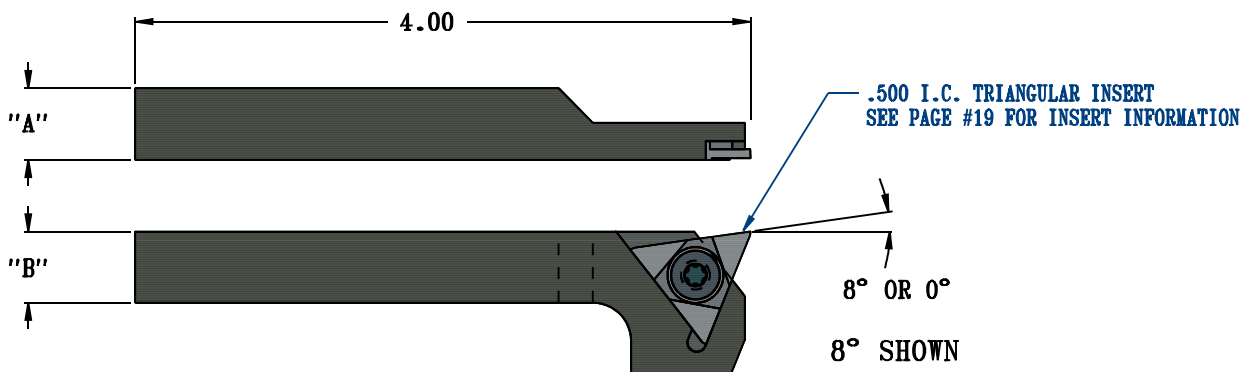

0° TOP RAKE TOOLHOLDERS	8° TOP RAKE TOOLHOLDERS	"A"	"B"	SCREW No.	WRENCH No.
CTD-9630-3	CTD-9631-3	.375	.375	CTD-4857	CTD-3619
CTD-9630-4	CTD-9631-4	.500	.500		
CTD-9630-5	CTD-9631-5	.625	.625		
CTD-9630-6	CTD-9631-6	.750	.750		
CTD-9630-8mm	CTD-9631-8mm	.315	.315		
CTD-9630-10mm	CTD-9631-10mm	.394	.394		
CTD-9630-12mm	CTD-9631-12mm	.472	.472		

ALTERNATE HEX
SCREW AND WRENCH
ORDER AS CTD-9492
FOR SCREW AND 1/8
HEX FOR WRENCH

TRIANGULAR INSERTED CNC & SWISS TYPE TOOLHOLDERS

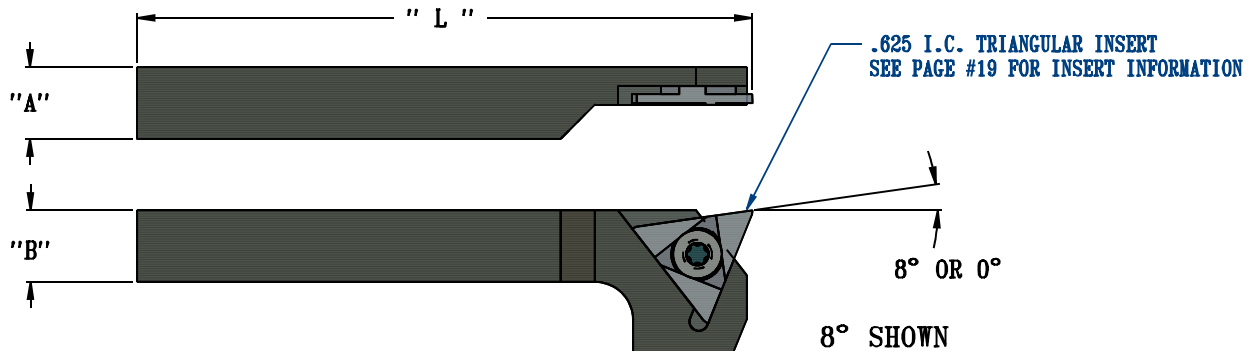
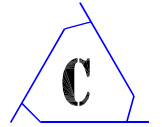
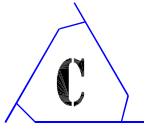

0° TOP RAKE TOOLHOLDERS	8° TOP RAKE TOOLHOLDERS	"A"	"B"	"L"	SCREW NUMBER	WRENCH NUMBER
CTD-9620-4	CTD-9621-4	.500	.500	5.00	CTD-4857	CTD-3619
CTD-9620-5	CTD-9621-5	.625	.625	6.00		
CTD-9620-6	CTD-9621-6	.750	.750	6.00		
CTD-9620-8	CTD-9621-8	1.000	1.000	6.00		
CTD-9620-12mm	CTD-9621-12mm	.472	.472	100mm		
CTD-9620-16mm	CTD-9621-16mm	.630	.630	150mm		
CTD-9620-20mm	CTD-9621-20mm	.787	.787	150mm		

ALTERNATE HEX SCREW AND WRENCH ORDER AS CTD-9492 FOR SCREW AND 1/8 HEX FOR WRENCH

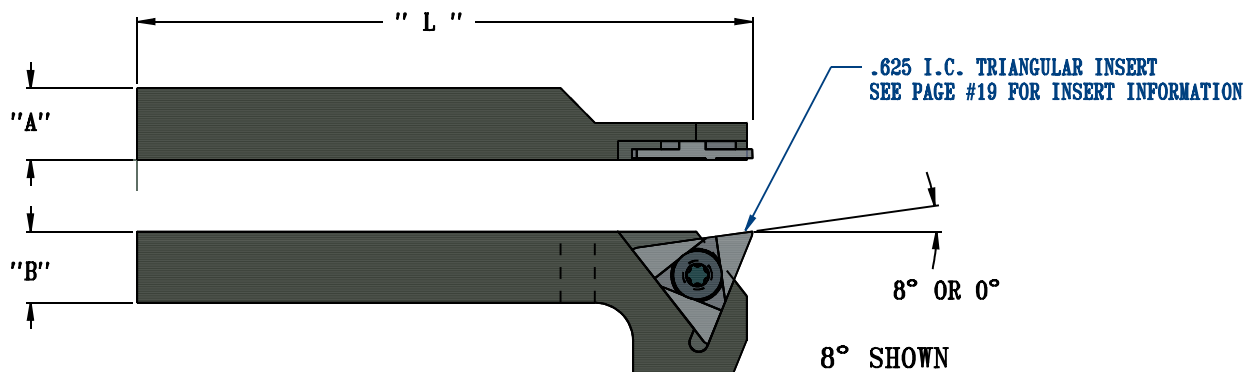

0° TOP RAKE TOOLHOLDERS	8° TOP RAKE TOOLHOLDERS	"A"	"B"	"L"	SCREW NUMBER	WRENCH NUMBER
CTD-9640-4	CTD-9641-4	.500	.500	5.00	CTD-4857	CTD-3619
CTD-9640-5	CTD-9641-5	.625	.625	6.00		
CTD-9640-6	CTD-9641-6	.750	.750	6.00		
CTD-9640-8	CTD-9641-8	1.000	1.000	6.00		
CTD-9640-12mm	CTD-9641-12mm	.472	.472	100mm		
CTD-9640-16mm	CTD-9641-16mm	.630	.630	150mm		
CTD-9640-20mm	CTD-9641-20mm	.787	.787	150mm		

ALTERNATE HEX SCREW AND WRENCH ORDER AS CTD-9492 FOR SCREW AND 1/8 HEX FOR WRENCH