

COMBINED SPOT DRILL & COUNTERSINK INSERTS

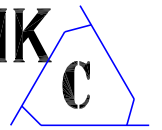

TWO FLUTE STANDARD RELIEF - CENTER CUTTING INSERTS

PATENT No. 7540-696

SEE PAGE #5 FOR HOLDERS

Left Hand Shown

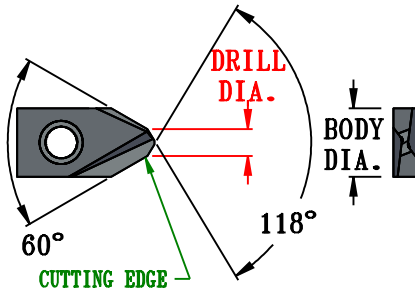

60° INSERTS

LEFT HAND INSERT No.	PLAIN TYPE	DRILL DIA.	BODY DIA.	RIGHT HAND INSERT No.
CDI-2-60-LH	#3	.109	.250	CDI-2-60
CDI-2.5-60-LH	#4	.125	.312	CDI-2.5-60
CDI-3.5-60-LH	#5	.187	.437	CDI-3.5-60
CDI-4-60-LH	#6	.218	.500	CDI-4-60

Right Hand Shown

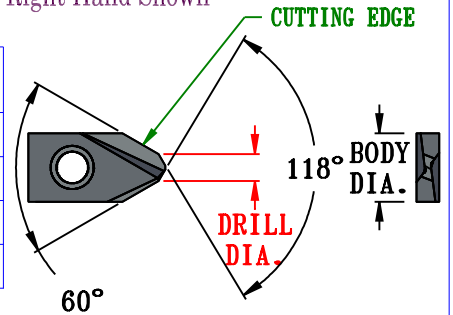

Left Hand Shown

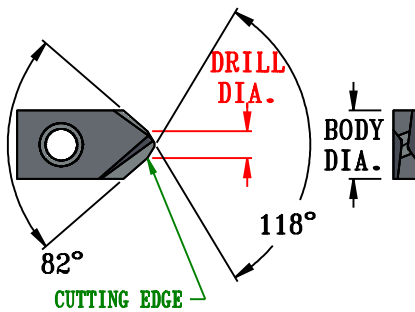

82° INSERTS

LEFT HAND INSERT No.	PLAIN TYPE	DRILL DIA.	BODY DIA.	RIGHT HAND INSERT No.
CDI-2-82-LH	#3	.109	.250	CDI-2-82
CDI-2.5-82-LH	#4	.125	.312	CDI-2.5-82
CDI-3.5-82-LH	#5	.187	.437	CDI-3.5-82
CDI-4-82-LH	#6	.218	.500	CDI-4-82

Right Hand Shown

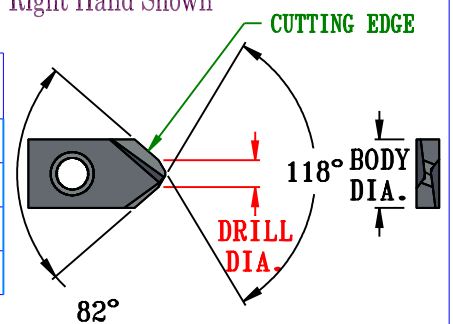

Left Hand Shown

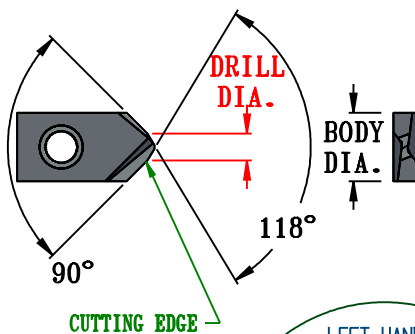

90° INSERTS

LEFT HAND INSERT No.	PLAIN TYPE	DRILL DIA.	BODY DIA.	RIGHT HAND INSERT No.
CDI-2-90-LH	#3	.109	.250	CDI-2-90
CDI-2.5-90-LH	#4	.125	.312	CDI-2.5-90
CDI-3.5-90-LH	#5	.187	.437	CDI-3.5-90
CDI-4-90-LH	#6	.218	.500	CDI-4-90

Right Hand Shown

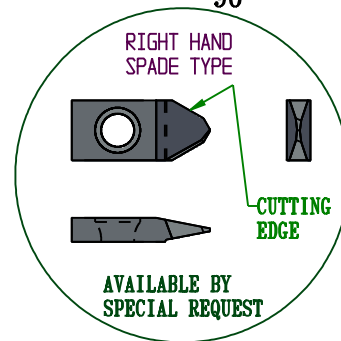
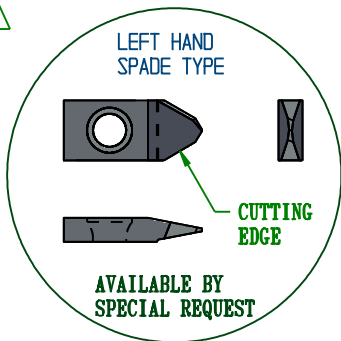
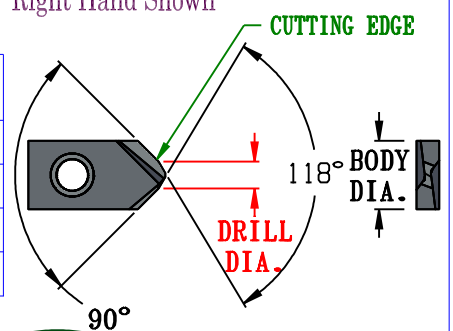

COMBINED SPOT DRILL & COUNTERSINK TOOLHOLDERS

PATENT No. 7540-696

SEE INSERTS ON PAGE #4

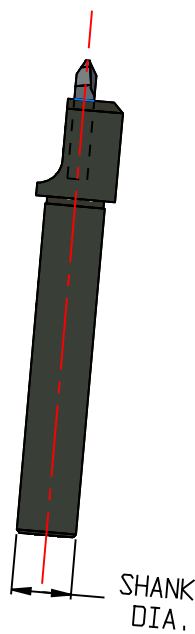
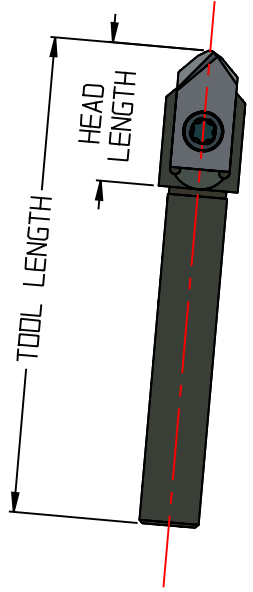
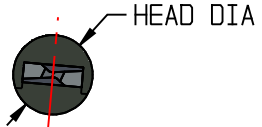
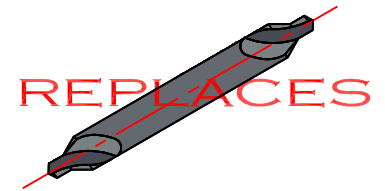

PLAIN TYPE # 3

TOOLHOLDER No.	TOOL LENGTH	SHANK DIA.	HEAD DIA.	HEAD LENGTH	SCREW No.	WRENCH No.
CDH-2-375-1.5	1.5	.375	.375	-----	CTD-3126	CTD-3344
CDH-2-375-2.5	2.5	.375	.375	-----	CTD-3126	CTD-3344
CDH-2-500-1.5	1.5	.500	.500	-----	CTD-3126	CTD-3344
CDH-2-500-2.5	2.5	.500	.500	-----	CTD-3126	CTD-3344
CDH-2-10MM-1.5	1.5	10MM	10MM	-----	CTD-3126	CTD-3344
CDH-2-10MM-2.5	2.5	10MM	10MM	-----	CTD-3126	CTD-3344

PLAIN TYPE # 4

TOOLHOLDER No.	TOOL LENGTH	SHANK DIA.	HEAD DIA.	HEAD LENGTH	SCREW No.	WRENCH No.
CDH-2.5-375-2.0	2.0	.375	.500	1.100	CTD-4110	CTD-4112
CDH-2.5-375-3.0	3.0	.375	.500	1.100	CTD-4110	CTD-4112
CDH-2.5-500-2.0	2.0	.500	-----	-----	CTD-4110	CTD-4112
CDH-2.5-500-3.0	3.0	.500	-----	-----	CTD-4110	CTD-4112
CDH-2.5-10MM-2.0	2.0	10MM	.500	1.100	CTD-4110	CTD-4112
CDH-2.5-10MM-3.0	3.0	10MM	.500	1.100	CTD-4110	CTD-4112

PLAIN TYPE # 5

TOOLHOLDER No.	TOOL LENGTH	SHANK DIA.	HEAD DIA.	HEAD LENGTH	SCREW No.	WRENCH No.
CDH-3.5-375-2.0	2.0	.375	.750	1.100	CTD-4111	CTD-4112
CDH-3.5-375-3.0	3.0	.375	.750	1.100	CTD-4111	CTD-4112
CDH-3.5-500-2.0	2.0	.500	.750	1.100	CTD-4111	CTD-4112
CDH-3.5-500-3.0	3.0	.500	.750	1.100	CTD-4111	CTD-4112
CDH-3.5-10MM-2.0	2.0	10MM	.750	1.100	CTD-4111	CTD-4112
CDH-3.5-10MM-3.0	3.0	10MM	.750	1.100	CTD-4111	CTD-4112

PLAIN TYPE # 6

TOOLHOLDER No.	TOOL LENGTH	SHANK DIA.	HEAD DIA.	HEAD LENGTH	SCREW No.	WRENCH No.
CDH-4-500-2.5	2.5	.500	.750	1.200	CTD-4111	CTD-4112
CDH-4-500-3.5	3.5	.500	.750	1.200	CTD-4111	CTD-4112
CDH-4-625-2.5	2.5	.625	.750	1.200	CTD-4111	CTD-4112
CDH-4-625-3.5	3.5	.625	.750	1.200	CTD-4111	CTD-4112
CDH-4-750-2.5	2.5	.750	.750	-----	CTD-4111	CTD-4112
CDH-4-750-3.5	3.5	.750	.750	-----	CTD-4111	CTD-4112