

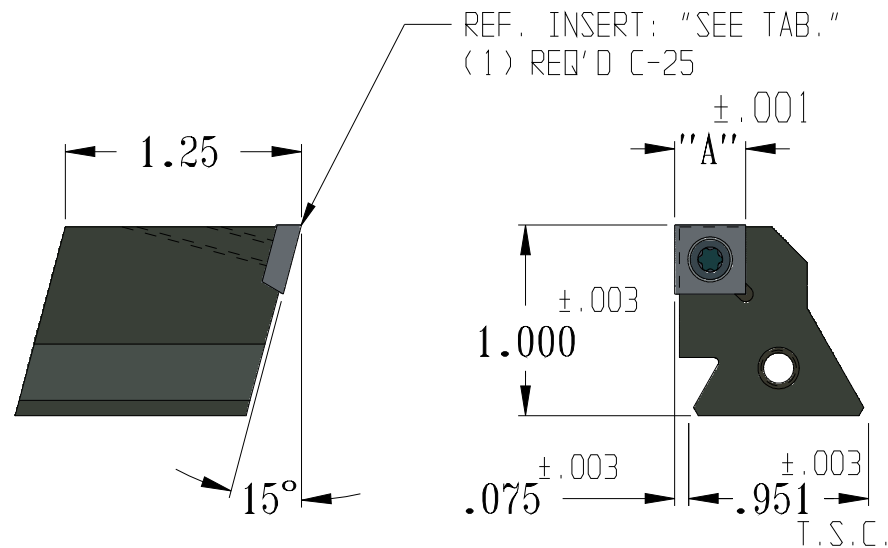

INSERTED DOVETAIL TOOLHOLDERS

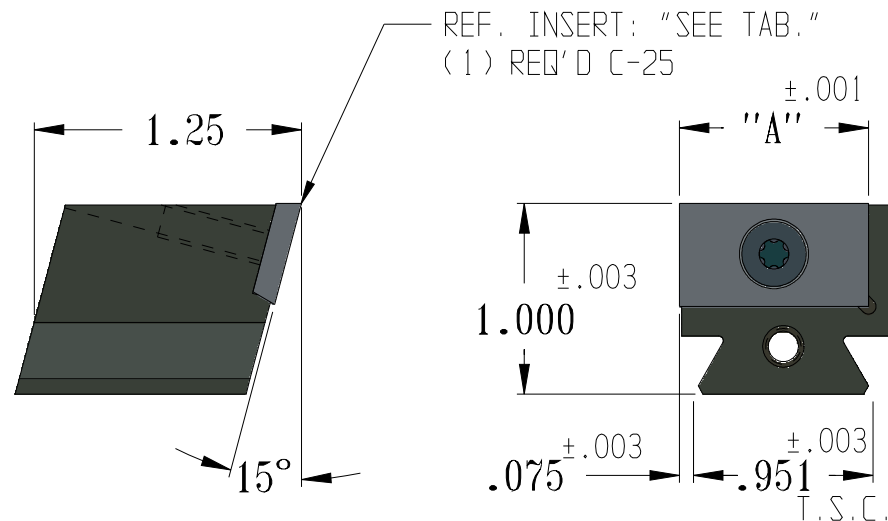

"A"	INSERT NUMBER	NUMBER OF CUTTING EDGES	TOOLHOLDER NUMBER	SCREW No.	WRENCH No.
.375	CTD-8516-375	(4)	CTD-8515-375	CTD-4110	CTD-4112
.500	CTD-8516-500	(4)	CTD-8515-500	CTD-4111	CTD-4112



"A"	INSERT NUMBER	NUMBER OF CUTTING EDGES	TOOLHOLDER NUMBER	SCREW No.	WRENCH No.
.750	CTD-8516-750	(2)	CTD-8515-750	CTD-4857	CTD-3619
1.000	CTD-8516-1.000	(2)	CTD-8515-1.000	CTD-4857	CTD-3619



ENLARGED VIEWS OF A FEW SPECIAL INSERT FORMS

DEPENDING ON FORM, INSERTS MAY BE SINGLE ENDED.

**SUBMIT YOUR SPECIAL TOOLING REQUIREMENTS TO US
TODAY FOR A QUOTATION USING THIS STYLE OF INSERT**



TM

WEDGE-LOC INSERTS & TOOLHOLDERS

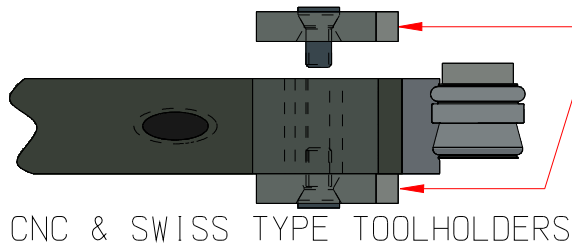
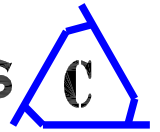

CNC & SWISS TYPE TOOLHOLDERS

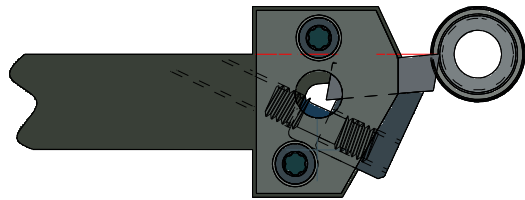

SEE PAGES 28,29 AND 30

SIDE PLATE CAN BE USED ON BOTH SIDES FOR MOST TOOLHOLDERS.

OUR PATENTED TECHNOLOGY CAN BE APPLIED TO ANY TOOLHOLDER.

ONCE THE TOOLHOLDER IS SET UP, MAKING DIFFERENT PARTS IS AS EASY AS CHANGING THE INSERT.

INSERT IS LOCKED IN BY THE WEDGE, WHICH CAN BE ACCESSED FROM FRONT OR BACK. THIS AIDS IN CHANGING INSERT.

BROWN & SHARP AND DAVENPORT TOOLHOLDERS

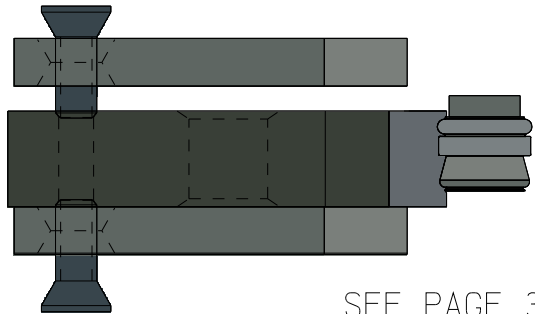

SEE PAGE 31.

OUR DESIGN STAFF WILL WORK CLOSELY WITH YOU TO PRODUCE INSERTS FOR YOUR PARTS.

WE WILL WORK TO MINIMIZE THE NUMBER OF OPERATIONS, HELPING WITH PRODUCTION.

ALL INSERTS HAVE A SPECIAL TOP FINISH FOR IMPROVED PART FINISH.

INSERTS ARE OFFERED IN DIFFERENT GRADES OF CARBIDE OR HIGH SPEED STEEL. INSERT COATINGS AND GRADE IS DEPENDENT ON YOUR PART MATERIAL AND TURNING SPEED.

DOVETAIL TOOLHOLDER

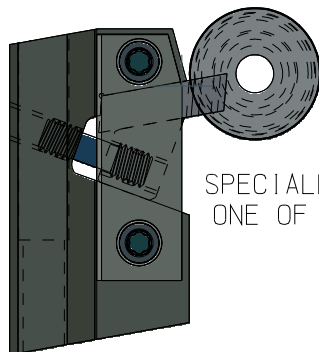
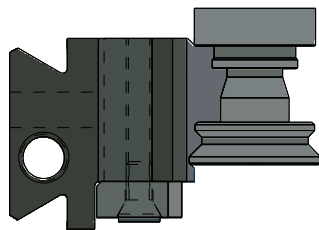

SPECIALLY DESIGNED FOR ONE OF OUR CUSTOMERS.

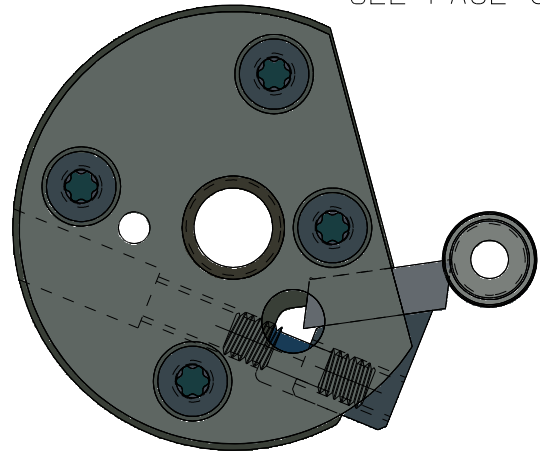

FOR A FRACTION OF THE COST OF NEW, OUR REGRIND SERVICE REMOVES ANY WEAR AND REAPPLIES SPECIAL FINISH. THE INSERT IS THEN RECOATED.

DUE TO OUR PATENTED DESIGN, INSERTS NEW OR REGROUND WILL LOCATE BACK TO CENTER HEIGHT AND LENGTH.

PATENT No. 7862261