



# INSERTED SPOT DRILL CENTER CUTTING INSERTS



## TWO FLUTE RADIAL RELIEF SPOT DRILL INSERTS

PATENT No. 7540-696

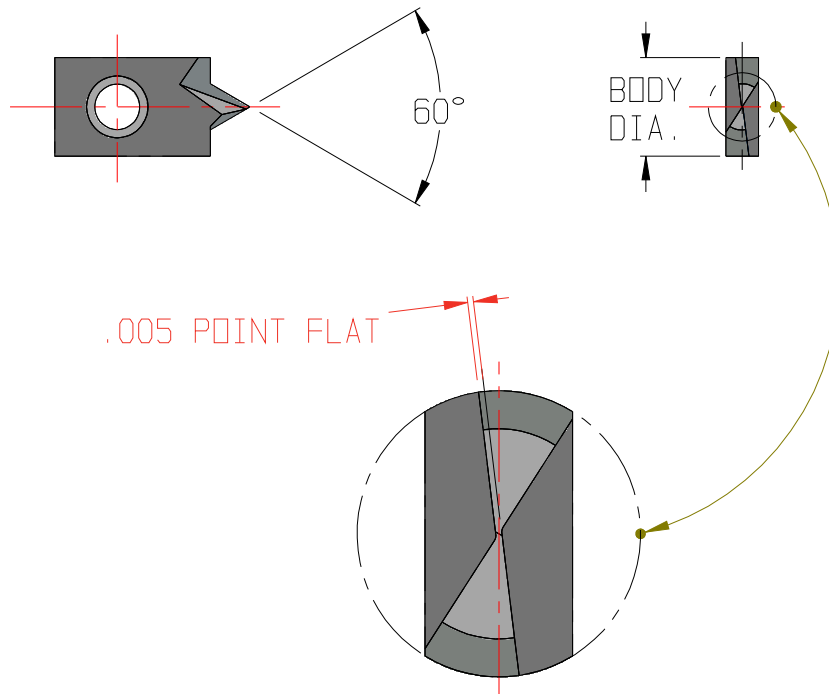

60° INSERTS		Right Hand Shown	
PLAIN TYPE	INSERT No.	POINT FLAT	BODY DIA.
#2	RSDI-2-60-005	.005	.250
#3	RSDI-3-60-005	.005	.375

### 60° INCLUDED RADIAL SPOT DRILL INSERT ADVANTAGES USE SDH HOLDERS ON PAGE 3

- 1) THE 60° INCLUDED ANGLE HAS RADIAL AND CONICAL RELIEF THAT IS OFFSET TO GIVE THE CUTTING EDGE MAXIMUM STRENGTH PLUS CLEARANCE.
- 2) THESE TWO SPOT DRILL INSERTS ARE CENTER CUTTING WITH THE ABILITY TO SPOT MATERIAL STARTING WITH A OUTSIDE DIAMETER OF .010.
- 3) THE SPEEDS FOR THESE TWO INSERTS NEED TO BE BETWEEN 5000 R.P.M. AND 8000 R.P.M. PLUS THE FEED RATE SHOULD BE BETWEEN .500 AND 1.000 PER MINUTE.



# INSERTED SPOT DRILL CENTER CUTTING INSERTS

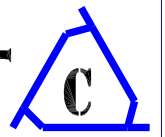

## TWO FLUTE STANDARD RELIEF SPOT DRILL INSERTS

" SPADE TYPE SPOT DRILL INSERTS AVAILABLE UPON REQUEST "

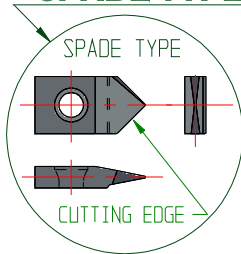

PATENT No. 7540-696

LETTER DESIGNATION	POINT FLAT
F = FINE POINT FLAT	.005
M = MEDIUM POINT FLAT	.015
H = HEAVY POINT FLAT	.034

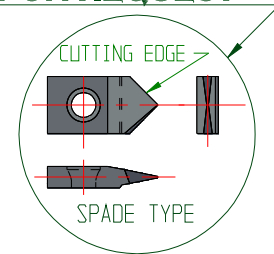

Left Hand

Ordering EXAMPLE  
SDI-2-82-F-LH

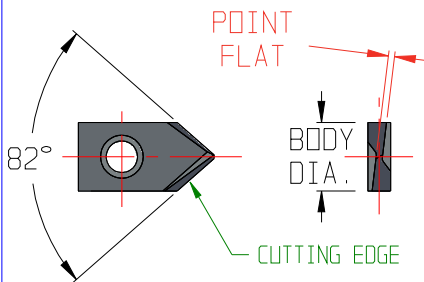

### 82° INSERTS

PLAIN TYPE	INSERT No.	POINT FLAT	ADD -LH FOR LEFT HAND	BODY DIA.
#2	SDI-2-82	F / M / H	SEE EXAMPLE	.250
#3	SDI-3-82	F / M / H	SEE EXAMPLE	.375
#4	SDI-4-82	F / M / H	SEE EXAMPLE	.500

Right Hand

Ordering EXAMPLE  
SDI-2-82-F

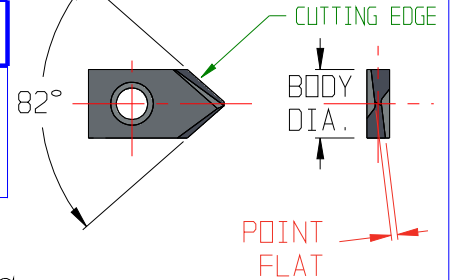

Left Hand

Ordering EXAMPLE  
SDI-3-90-M-LH

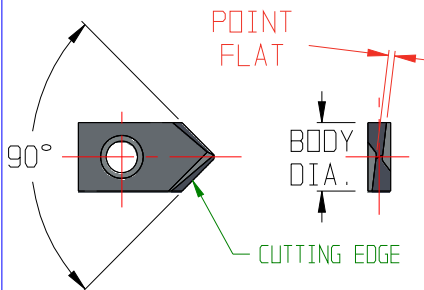

### 90° INSERTS

PLAIN TYPE	INSERT No.	POINT FLAT	ADD -LH FOR LEFT HAND	BODY DIA.
#2	SDI-2-90	F / M / H	SEE EXAMPLE	.250
#3	SDI-3-90	F / M / H	SEE EXAMPLE	.375
#4	SDI-4-90	F / M / H	SEE EXAMPLE	.500

Right Hand

Ordering EXAMPLE  
SDI-3-90-M

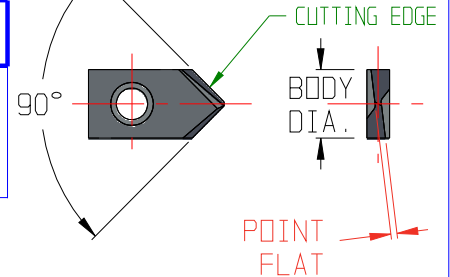

Left Hand

Ordering EXAMPLE  
SDI-4-120-H-LH

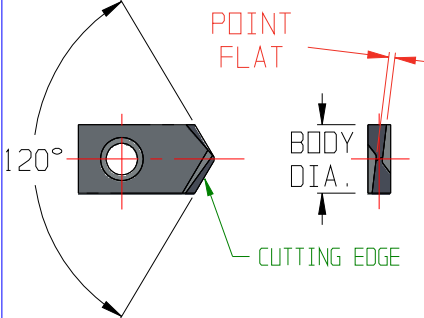

### 120° INSERTS

PLAIN TYPE	INSERT No.	POINT FLAT	ADD -LH FOR LEFT HAND	BODY DIA.
#2	SDI-2-120	F / M / H	SEE EXAMPLE	.250
#3	SDI-3-120	F / M / H	SEE EXAMPLE	.375
#4	SDI-4-120	F / M / H	SEE EXAMPLE	.500

Right Hand

Ordering EXAMPLE  
SDI-4-120-H

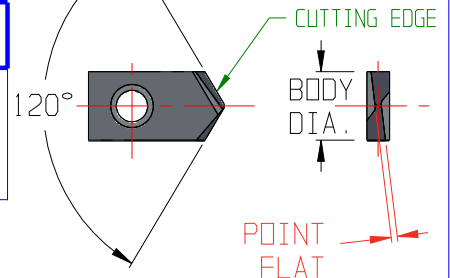



# INSERTED SPOT DRILL TOOLHOLDERS



PATENT No. 7540-696

SEE INSERTS PAGES #1, #2.

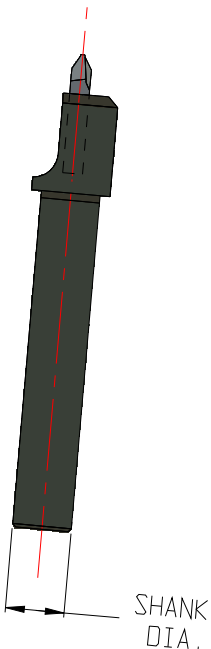
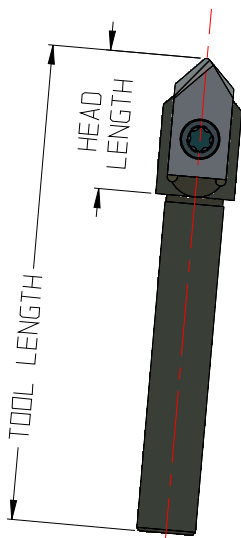
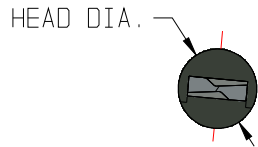

## PLAIN TYPE # 2

TOOLHOLDER No.	TOOL LENGTH	SHANK DIA.	HEAD DIA.	HEAD LENGTH	SCREW No.	WRENCH No.
SDH-2-250-2.0	2.0	.250	.405	.690	CTD-3126	CTD-3344
SDH-2-375-1.5	1.5	.375	-----	-----	CTD-3126	CTD-3344
SDH-2-375-2.5	2.5	.375	-----	-----	CTD-3126	CTD-3344
SDH-2-500-2.0	2.0	.500	-----	-----	CTD-3126	CTD-3344
SDH-2-500-3.0	3.0	.500	-----	-----	CTD-3126	CTD-3344
SDH-2-625-5.0	5.0	.625	-----	-----	CTD-3126	CTD-3344
SDH-2-750-5.0	5.0	.750	-----	-----	CTD-3126	CTD-3344
SDH-2-1.000-5.0	5.0	1.000	-----	-----	CTD-3126	CTD-3344
SDH-2-10MM-1.5	1.5	10MM	-----	-----	CTD-3126	CTD-3344
SDH-2-10MM-2.5	2.5	10MM	-----	-----	CTD-3126	CTD-3344

## PLAIN TYPE # 3

TOOLHOLDER No.	TOOL LENGTH	SHANK DIA.	HEAD DIA.	HEAD LENGTH	SCREW No.	WRENCH No.
SDH-3-375-2.0	2.0	.375	.625	.900	CTD-4110	CTD-4112
SDH-3-375-3.0	3.0	.375	.625	.900	CTD-4110	CTD-4112
SDH-3-500-2.0	2.0	.500	.625	.900	CTD-4110	CTD-4112
SDH-3-500-3.0	3.0	.500	.625	.900	CTD-4110	CTD-4112
SDH-3-625-3.0	3.0	.625	-----	-----	CTD-4110	CTD-4112
SDH-3-625-5.0	5.0	.625	-----	-----	CTD-4110	CTD-4112
SDH-3-750-3.5	3.5	.750	-----	-----	CTD-4110	CTD-4112
SDH-3-750-5.0	5.0	.750	-----	-----	CTD-4110	CTD-4112
SDH-3-1.000-5.0	5.0	1.000	-----	-----	CTD-4110	CTD-4112
SDH-3-10MM-2.0	2.0	10MM	.500	.900	CTD-4110	CTD-4112
SDH-3-10MM-3.0	3.0	10MM	.500	.900	CTD-4110	CTD-4112
SDH-3-16MM-3.0	3.0	16MM	-----	-----	CTD-4110	CTD-4112

## PLAIN TYPE # 4

TOOLHOLDER No.	TOOL LENGTH	SHANK DIA.	HEAD DIA.	HEAD LENGTH	SCREW No.	WRENCH No.
SDH-4-375-3.5	3.5	.375	.750	1.20	CTD-4111	CTD-4112
SDH-4-500-2.5	2.5	.500	.750	1.20	CTD-4111	CTD-4112
SDH-4-500-3.5	3.5	.500	.750	1.20	CTD-4111	CTD-4112
SDH-4-625-2.5	2.5	.625	.750	1.20	CTD-4111	CTD-4112
SDH-4-625-3.5	3.5	.625	.750	1.20	CTD-4111	CTD-4112
SDH-4-625-5.0	5.0	.625	.750	1.20	CTD-4111	CTD-4112
SDH-4-750-2.5	2.5	.750	-----	-----	CTD-4111	CTD-4112
SDH-4-750-3.5	3.5	.750	-----	-----	CTD-4111	CTD-4112
SDH-4-750-5.0	5.0	.750	-----	-----	CTD-4111	CTD-4112
SDH-4-1.000-5.0	5.0	1.000	-----	-----	CTD-4111	CTD-4112