

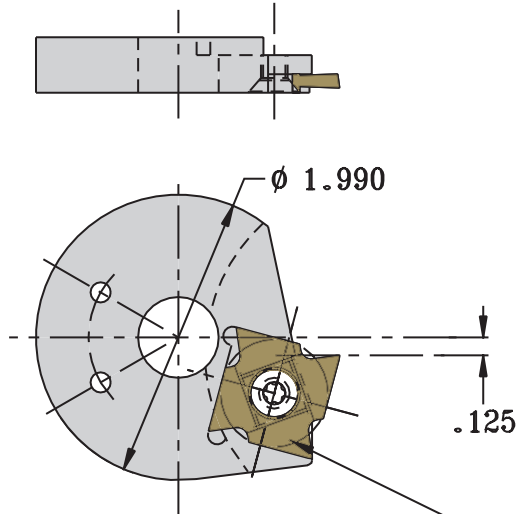

DAVENPORT CUT-OFF TOOLHOLDERS

PATENT No. D307859

DAVENPORT REGULAR C/O TOOLHOLDER



THE INSERT SHOWN IS RIGHT HAND
EXAMPLE - SLPR-078

TOOLHOLDER No.	SCREW No.	WRENCH No.
DPCL-375-6	CTD-3341	CTD-3342

SLPR - STYLE INSERT (.750 I.C.)

DAVENPORT OVERSIZE C/O TOOLHOLDER

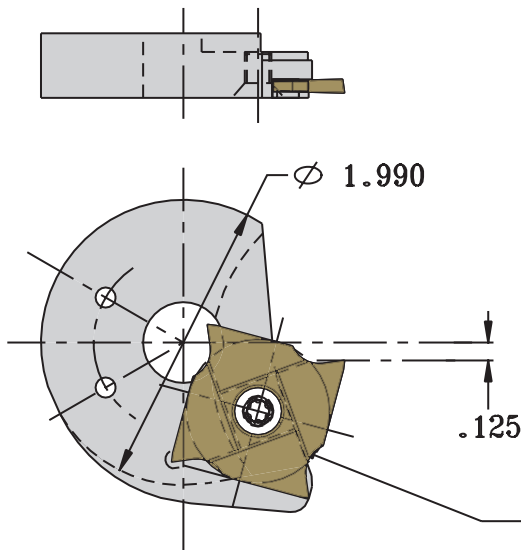

THE INSERT SHOWN IS RIGHT HAND
EXAMPLE - ELPR-094

TOOLHOLDER No.	SCREW No.	WRENCH No.
DPCL-437-8	CTD-4857	CTD-3342

ELPR - STYLE INSERT (1.000 I.C.)



DAVENPORT DOVETAIL INSERTED - TOOLHOLDERS

DAVENPORT DOVETAIL TOOLHOLDERS WITH (4) CUTTING EDGES

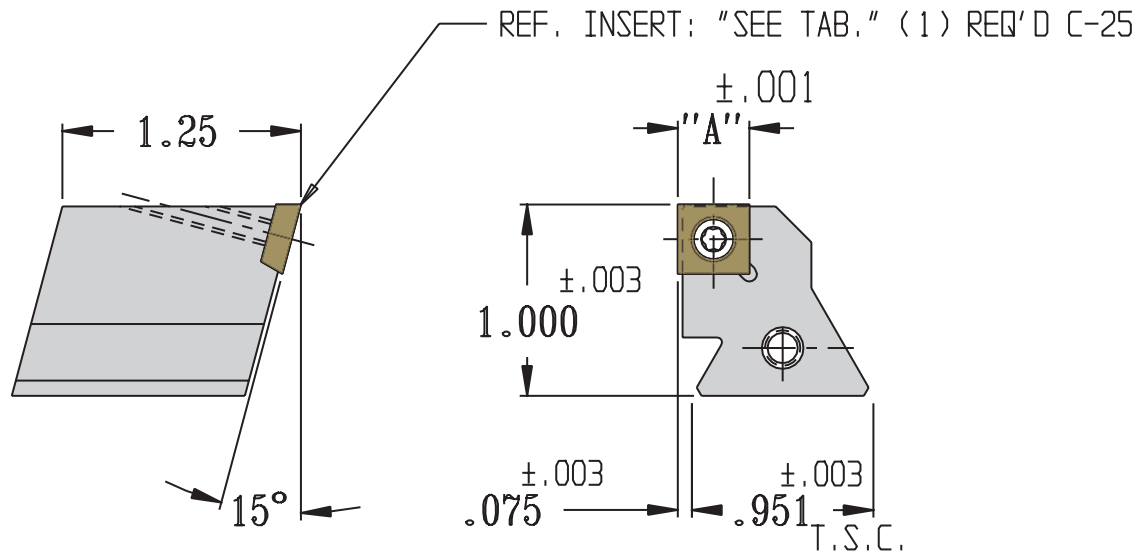

"A"	INSERT NUMBER	NUMBER OF CUTTING EDGES	TOOLHOLDER NUMBER	SCREW No.	WRENCH No.
.375	CTD-8516-375	(4)	CTD-8515-375	CTD-4110	CTD-4112
.500	CTD-8516-500	(4)	CTD-8515-500	CTD-4111	CTD-4112

DAVENPORT DOVETAIL TOOLHOLDERS WITH (2) CUTTING EDGES

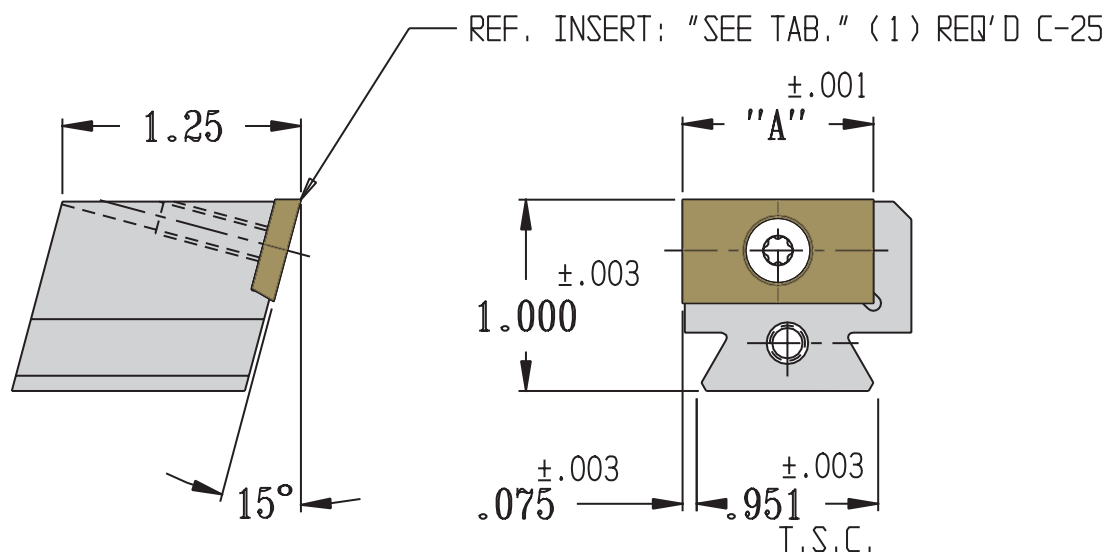

"A"	INSERT NUMBER	NUMBER OF CUTTING EDGES	TOOLHOLDER NUMBER	SCREW No.	WRENCH No.
.750	CTD-8516-750	(2)	CTD-8515-750	CTD-4857	CTD-3342
1.000	CTD-8516-1.000	(2)	CTD-8515-1.000	CTD-4857	CTD-3342