

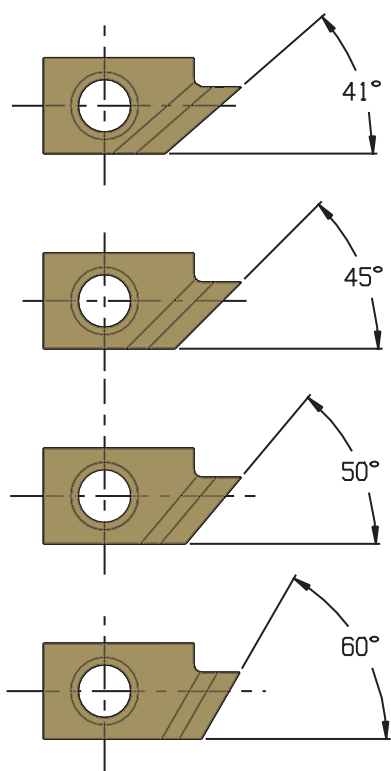

INSERTABLE COUNTERSINK INSERTS

PATENT Nos. D396,865 & 5,827,019



| | |
|--------------------|-----------------|
| 41° INSERTS | Left Hand Shown |
| R.H. INSERT No. | L.H. INSERT No. |
| CSI-41R | CSI-41 |

| | |
|--------------------|-----------------|
| 45° INSERTS | Left Hand Shown |
| R.H. INSERT No. | L.H. INSERT No. |
| CSI-45R | CSI-45 |

| | |
|--------------------|-----------------|
| 50° INSERTS | Left Hand Shown |
| R.H. INSERT No. | L.H. INSERT No. |
| CSI-50R | CSI-50 |

| | |
|--------------------|-----------------|
| 60° INSERTS | Left Hand Shown |
| R.H. INSERT No. | L.H. INSERT No. |
| CSI-60R | CSI-60 |

STANDARD INSERTS IN SPECIAL TOOLHOLDERS

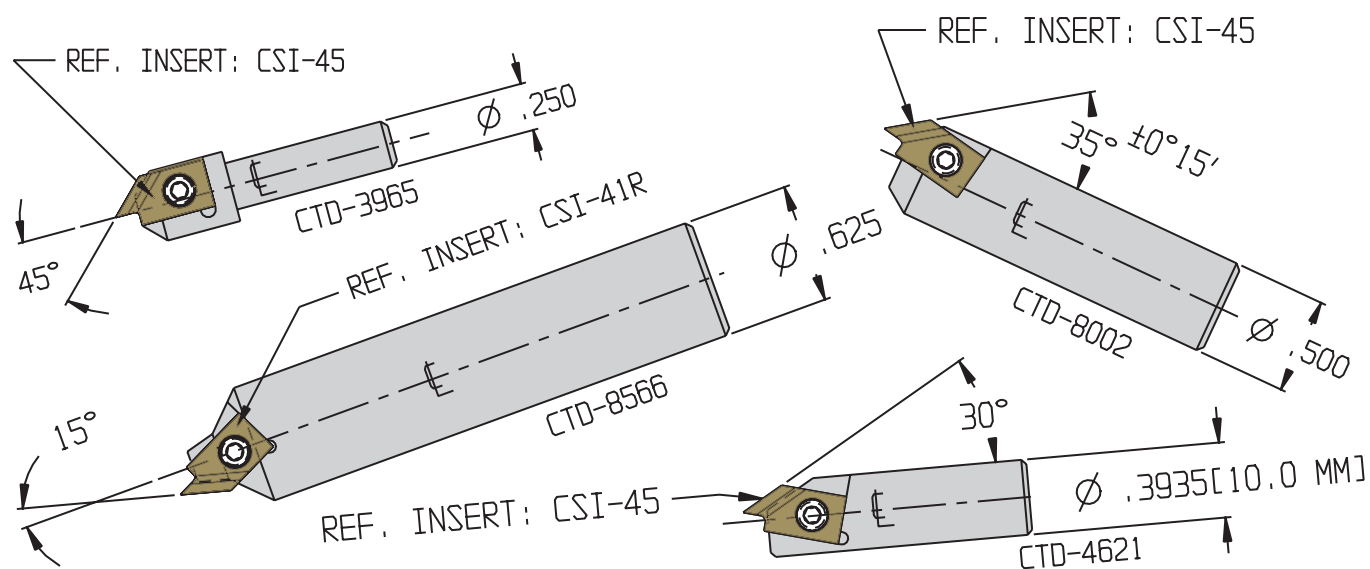



INSERTED COUNTERSINK TOOLHOLDERS

PATENT Nos. D396,865 & 5,827,019

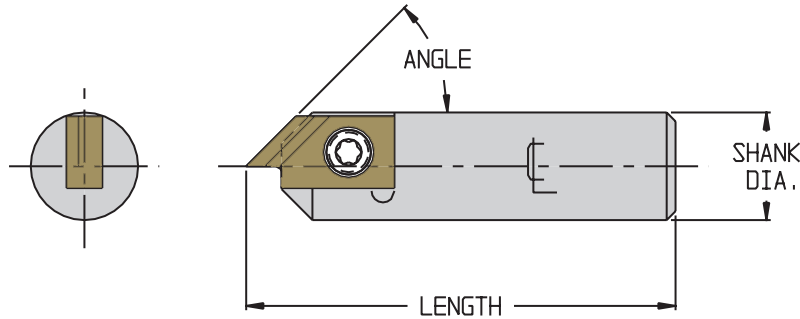

LEFT HAND SHOWN

FEATURES

- * COUNTERSINK RANGE FROM .035 TO ϕ .325
- * BACKWORKING LEFT HAND CUTTING
- * CHAMFERING BACK END OF PART I.D.
- * LARGER RANGES AVAILABLE ON REQUEST
- * THREE OTHER LENGTHS ARE AVAILABLE.
 EXAMPLE: CSH-90-500-S IS 1.0 D.A.L.
 CSH-90-500-XL IS 2.0 D.A.L.
 CSH-90-500-XXL IS 2.5 D.A.L.

LEFT HAND

| INCLUDED ANGLE | TOOLHOLDER No. | TOOL LENGTH | SHANK DIA. | INSERT ANGLE | INSERT NO. | SCREW No. | WRENCH No. |
|----------------|----------------|-------------|------------|--------------|------------|-----------|------------|
| 82° | CSH-90-375 | 1.5 | .375 | 41° | CSI-41 | CTD-3126 | CTD-3344 |
| 90° | CSH-90-375 | 1.5 | .375 | 45° | CSI-45 | CTD-3126 | CTD-3344 |
| 100° | CSH-90-375 | 1.5 | .375 | 50° | CSI-50 | CTD-3126 | CTD-3344 |
| 120° | CSH-120-375 | 1.5 | .375 | 60° | CSI-60 | CTD-3126 | CTD-3344 |
| 90° | CSH-90-437 | 1.5 | .4375 | 45° | CSI-45 | CTD-3126 | CTD-3344 |
| 82° | CSH-90-500 | 1.5 | .500 | 41° | CSI-41 | CTD-3126 | CTD-3344 |
| 90° | CSH-90-500 | 1.5 | .500 | 45° | CSI-45 | CTD-3126 | CTD-3344 |
| 100° | CSH-90-500 | 1.5 | .500 | 50° | CSI-50 | CTD-3126 | CTD-3344 |
| 120° | CSH-120-500 | 1.5 | .500 | 60° | CSI-60 | CTD-3126 | CTD-3344 |
| 90° | CSH-90-625 | 1.5 | .625 | 45° | CSI-45 | CTD-3126 | CTD-3344 |
| 90° | CSH-90-750 | 1.5 | .750 | 45° | CSI-45 | CTD-3126 | CTD-3344 |
| 90° | CSH-90-10MM | 1.5 | .3937 | 45° | CSI-45 | CTD-3126 | CTD-3344 |

RIGHT HAND

| INCLUDED ANGLE | TOOLHOLDER No. | TOOL LENGTH | SHANK DIA. | INSERT ANGLE | INSERT NO. | SCREW No. | WRENCH No. |
|----------------|----------------|-------------|------------|--------------|------------|-----------|------------|
| 82° | CSH-90-375R | 1.5 | .375 | 41° | CSI-41R | CTD-3126 | CTD-3344 |
| 90° | CSH-90-375R | 1.5 | .375 | 45° | CSI-45R | CTD-3126 | CTD-3344 |
| 100° | CSH-90-375R | 1.5 | .375 | 50° | CSI-50R | CTD-3126 | CTD-3344 |
| 120° | CSH-120-375R | 1.5 | .375 | 60° | CSI-60R | CTD-3126 | CTD-3344 |
| 90° | CSH-90-437R | 1.5 | .4375 | 45° | CSI-45R | CTD-3126 | CTD-3344 |
| 82° | CSH-90-500R | 1.5 | .500 | 41° | CSI-41R | CTD-3126 | CTD-3344 |
| 90° | CSH-90-500R | 1.5 | .500 | 45° | CSI-45R | CTD-3126 | CTD-3344 |
| 100° | CSH-90-500R | 1.5 | .500 | 50° | CSI-50R | CTD-3126 | CTD-3344 |
| 120° | CSH-120-500R | 1.5 | .500 | 60° | CSI-60R | CTD-3126 | CTD-3344 |
| 90° | CSH-90-625R | 1.5 | .625 | 45° | CSI-45R | CTD-3126 | CTD-3344 |
| 90° | CSH-90-750R | 1.5 | .750 | 45° | CSI-45R | CTD-3126 | CTD-3344 |
| 90° | CSH-90-10MMR | 1.5 | .3937 | 45° | CSI-45R | CTD-3126 | CTD-3344 |